

5 Frame Plunger Pump

Standard Models 310, 340, 350

Sleeved Models 310S, 340S, 350S

W770 Models 310W, 340W, 350W

FEATURES

Superior Design

- Triplex plunger design gives smoother liquid flow.
- Hi-Pressure Seals are completely lubricated and cooled by the liquid being pumped.
- Inlet and discharge valve assemblies interchange for easier maintenance.
- Lubricated Lo-Pressure Seal provides double protection against external leakage.
- Oil bath crankcase assures optimum lubrication.
- Close tolerance concentricity of the ceramic plunger maximizes seal life.
- Convenient direct drive electric motor options.

Quality Materials

- Precision design 304 stainless steel valves and seats are hardened and polished for ultimate seating and extended valve life.
- Forged brass, sleeved forged brass or special W770 alloy manifolds for strength and corrosion resistance.
- Special concentric, high-density, polished, solid ceramic plungers provide a true wear surface and extended seal life.
- Specially formulated, CAT PUMP exclusive, Hi-Pressure Seals offer unmatched performance and seal life.
- Die cast aluminum crankcase provides high strength, minimum weight and precision tolerance control.
- Chrome-moly crankshaft gives unmatched strength and surface hardness.
- Oversized crankshaft bearings with greater loading capacity mean longer bearing life.

Easy Maintenance

- Wet-end is easily serviced without entering crankcase, requiring less time and effort.
- Valve assemblies are accessible without disturbing piping, for quick service.
- Preset packings mean no packing gland adjustment is necessary, reducing maintenance costs.

⚠ WARNING

All systems require both a primary pressure regulating device (i.e., regulator, unloader) and a secondary pressure safety relief device (i.e., pop-off valve, safety valve). Failure to install such relief devices could result in personal injury or damage to the pump or to system components. CAT PUMPS does not assume any liability or responsibility for the operation of a customer's high pressure system.

SPECIFICATIONS

	U.S. Measure	Metric Measure
MODEL 310, 310S, 310W		
Flow	4.0 GPM	(15 L/M)
Pressure Range	100 to 2200 PSI	(7 to 155 BAR)
RPM	950 RPM	(950 RPM)
Inlet Pressure Range	-5 to 60 PSI	(-0.35 to 4 BAR)
Stroke	0.709"	(18 mm)
MODEL 340, 340S, 340W Direct Drive		
Flow	4.0 GPM	(15 L/M)
Pressure Range	100 to 1800 PSI	(7 to 125 BAR)
RPM	1725 RPM	(1725 RPM)
Inlet Pressure Range	Flooded to 60 PSI	(Flooded to 4 BAR)
Stroke	0.394"	(10 mm)
MODEL 350, 350S, 350W Direct Drive		
Flow*	5.0 GPM	(19 L/M)
Pressure Range	100 to 1500 PSI	(7 to 105 BAR)
RPM	1725 RPM	(1725 RPM)
Inlet Pressure Range	Flooded to 60 PSI	(Flooded to 4 BAR)
Stroke	0.472"	(12 mm)

*This specification for intermittent, fresh water duty.

COMMON SPECIFICATIONS

Bore	0.787"	(20 mm)
Crankcase Capacity	18 oz.	(0.55 L)
Maximum Liquid Temperature	160°F	(71°C)
Above 130°F call CAT PUMPS for inlet conditions and elastomer recommendations.		
Inlet Ports (2)	1/2" NPTF	(1/2" NPTF)
Discharge Ports (2)	3/8" NPTF	(3/8" NPTF)
Shaft Diameter	0.787"	(20 mm)
Weight	19.8 lbs.	(9 kg)
Dimensions	11.73 x 10.0 x 5.24"	(298 x 254 x 133 mm)

ELECTRIC HORSEPOWER REQUIREMENTS

MODEL	FLOW		PRESSURE					MOTOR PULLEY SIZE	
			PSI 1200	PSI 1500	PSI 1800	PSI 2000	PSI 2200	Using 1725 RPM Motor & Std. 8" Pump Pulley	
	U.S. GPM	L/M	BAR 85	BAR 105	BAR 125	BAR 140	BAR 155	RPM	Pulley O.D.
310	5.0	19	4.1	5.1	N/A	N/A	N/A	1190	5.5
	4.0	15	3.3	4.1	5.0	5.5	6.0	950	4.4
	3.0	11.4	2.5	3.1	3.7	4.2	4.5	713	3.3
340	4.0	15	3.3	4.1	5.0	N/A	N/A	1725	Direct Drive
350	5.0	19	4.1	5.1	N/A	N/A	N/A	1725	Direct Drive

DETERMINING THE PUMP R.P.M. $\frac{\text{Rated G.P.M.}}{\text{Rated R.P.M.}}$ = "Desired" G.P.M. "Desired" R.P.M.

DETERMINING THE REQUIRED H.P. $\frac{\text{GPM x PSI}}{1460}$ = Electric Brake H. P. Required

DETERMINING MOTOR PULLEY SIZE $\frac{\text{Motor Pulley O.D.}}{\text{Pump R.P.M.}}$ = $\frac{\text{Pump Pulley O.D.}}{\text{Motor R.P.M.}}$

See complete Drive Packages [Incls: Pulleys, Belts, Hubs, Key] Tech Bulletin 003.
Refer to pump **Service Manual** for repair procedure, additional technical information and **pump warranty**.

"Customer confidence is our greatest asset"

PARTS LIST

ITEM	PART NUMBER						DESCRIPTION	QTY
	310		310S		310W			
	340		340S		340W			
	350	MATL	350S	MATL	350W	MATL		
2	30057	STL	30057	STL	30057	STL	Key (M6x6x25)	1
5	92519	STZP	92519	STZP	92519	STZP	Screw, Sems HHC (M6x16)	8
	125824	STCP R	125824	STCP R	125824	STCP R	Screw, Sems HHC (M6x16)	8
8	43344	AL	43344	AL	43344	AL	Cover, Bearing	1/2
10	43343	NBR	43343	NBR	43343	NBR	O-Ring, Bearing Cover - 70D	2
11	43222	NBR	43222	NBR	43222	NBR	Seal, Oil, Crankshaft - (310, 350-2) (340-1)	1/2
15	14480	STL	14480	STL	14480	STL	Bearing, Ball	2
20	45883	HS	45883	HS	45883	HS	Rod, Connecting Assy [09/05]	3
25	43342	FCM	43342	FCM	43342	FCM	Crankshaft, Dual End - 310, 310S, 310W	1
	44945	FCM	44945	FCM	44945	FCM	Crankshaft, Single End - 340, 340S, 340W	1
	43838	FCM	43838	FCM	43838	FCM	Crankshaft, Dual End - 350, 350S, 350W	1
30	44949	AL	44949	AL	44949	AL	Cover, Blind Shaft - 340	1
31	828710	—	828710	—	828710	—	Protector, Oil Cap w/Foam Gasket	1
32	43211	ABS	43211	ABS	43211	ABS	Cap, Oil Filler	1
33	14177	NBR	14177	NBR	14177	NBR	O-Ring, Filler Cap - 70D	1
37	92241	—	92241	—	92241	—	Gauge, Oil, Bubble w/Gasket	1
38	44428	NBR	44428	NBR	44428	NBR	Gasket, Flat, Oil Gauge - 80D	1
40	92520	STZP	92520	STZP	92520	STZP	Screw, Sems HHC (M6x20)	4
	126541	STCP R	126541	STCP R	126541	STCP R	Screw, Sems HHC (M6x20)	4
48	25625	STCP	25625	STCP	25625	STCP	Plug, Drain (1/4"x19 BSP)	1
49	23170	NBR	23170	NBR	23170	NBR	O-Ring, Drain Plug - 70D	1
50	48772	AL	48772	AL	48772	AL	Cover, Rear [10/01]	1
51	48773	NBR	48773	NBR	48773	NBR	O-Ring, Rear Cover [10/01]	1
53	48769	AL	48769	AL	48769	AL	Crankcase [05/02]	1
56	43355	POP	43355	POP	43355	POP	Pan, Oil	1
64	43351	CM	43351	CM	43351	CM	Pin, Crosshead	3
65	43365	ZZCP	43365	ZZCP	43365	ZZCP	Rod, Plunger	3
70	43228	NBR	43228	NBR	43228	NBR	Seal, Oil, Crankcase	3
75	43328	S	43328	S	43328	S	Slinger, Barrier	3
88	45697	S	45697	S	45697	S	Washer, Keyhole (M18)	3
90	43367	CC	43367	CC	43367	CC	Plunger (M20x72)	3
96	43235	PTFE	43235	PTFE	43235	PTFE	Back-up-Ring, Plunger Retainer	3
97	17399	NBR	17399	NBR	17399	NBR	O-Ring, Plunger Retainer - 80D	3
	14160	FPM	14160	FPM	14160	FPM	O-Ring, Plunger Retainer - 70D	3
	◆ 46204	EPDM	◆ 46204	EPDM	◆ 46204	EPDM	O-Ring, Plunger Retainer - 70D	3
98	45891	CU	45891	CU	45891	CU	Gasket	3
99	104360	S	104360	S	104360	S	Retainer, Plunger w/Stud	3
100	45688	PVDF	45688	PVDF	45688	PVDF	Retainer, 2-Pc [04/06]	3
101	43302	—	43302	—	43302	—	Wick, Long Tab	3
106	43305	NBR	43305	NBR	43305	NBR	Seal, LPS w/S-Spg	3
	45153	FPM	45153	FPM	45153	FPM	Seal, LPS w/SS-Spg	3
	◆ 48429	EPDM	◆ 48429	EPDM	◆ 48429	EPDM	Seal, LPS w/SS-Spg	3
120	45679	BB	45679	BB	45679	BB	Case, Seal	3
121	14200	NBR	14200	NBR	14200	NBR	O-Ring, Seal Case - 70D	3
	11719	FPM	11719	FPM	11719	FPM	O-Ring, Seal Case	3
	◆ 48907	EPDM	◆ 48907	EPDM	◆ 48907	EPDM	O-Ring, Seal Case	3
125	43307	SNG	43307	SNG	43307	SNG	Seal, HPS w/S	3
	44936	FPM	44936	FPM	44936	FPM	Seal, HPS w/SS	3
	46667	HT*	46667	HT*	46667	HT*	Seal, HPS "Hi-Temp", 2-Pc w/S-Support	3
139	22179	BBCP	22179	BBCP	22179	BBCP	Plug, Inlet (1/2" NPT)	1
162	48361	D	48361	D	48361	D	Back-up-Ring, Seat	6
163	43358	NBR	43358	NBR	43358	NBR	O-Ring, Seat - 70D	6
	44938	FPM	44938	FPM	44938	FPM	O-Ring, Seat - 70D	6
	◆ 48908	EPDM	◆ 48908	EPDM	◆ 48908	EPDM	O-Ring, Seat	6
164	43725	S	43725	S	43725	S	Seat	6
166	43723	S	43723	S	43723	S	Valve	6
167	43750	S	43750	S	43750	S	Spring, Valve	6
168	44565	PVDF	44565	PVDF	44565	PVDF	Retainer, Valve Spring	6
172	17615	NBR	17615	NBR	17615	NBR	O-Ring, Valve Plug - 75D	6
	15855	FPM	15855	FPM	15855	FPM	O-Ring, Valve Plug -70D	6
	◆ 48431	EPDM	◆ 48431	EPDM	◆ 48431	EPDM	O-Ring, Valve Plug -75D	6
174	43849	BBCP	43849	BBCP	43849	BBCP	Plug, Valve	6
185	44837	BBCP	—	—	46825	W770	Head, Manifold	1
	—	—	46278	FBB	—	—	Head, Manifold, Sleeved	1
188	124396	STZP	124396	STZP	124396	STZP	Screw, Sems HSH (M10x35) [01/04]	2
	126520	STCP R	126520	STCP R	126520	STCP R	Screw, Sems HSH (M10x35)	2
250	118672	STCP	118672	STCP	118672	STCP	Protector, Shaft (Belt Drive Only)	1
255	30243	STZP	30243	STZP	30243	STZP	Mount, Direct (Belt Drive Only)	1
260	30611	STZP	30611	STZP	30611	STZP	Mounting, Angle Rail - B	1
	—	—	—	—	—	—	(28499,30900,30910,30920) (Belt Drive Only)	1
265	30659	—	30659	—	30659	—	Mount, Assy	1
	—	—	—	—	—	—	(30611,30633,118672) (Belt Drive Only)	1
270	30633	STL	30633	STL	30633	STL	Assy, Pulley & Key (30058,30057) (Belt Drive Only)	1
275	30944	STL	30944	STL	30944	STL	Assy, Hub & Key (M20 w/M6 Keyway) (Belt Drive Only)	1
	—	—	—	—	—	—	[See Drive Packages, Tech Bulletin 003]	1
283	34334	—	34334	—	34334	—	Kit, Oil Drain	1
298	34962	STZP	34962	STZP	34962	STZP	Clutch Assy, Single Groove, 20mm, 12VDC	1
	34963	STZP	34963	STZP	34963	STZP	Clutch Assy, Dual Groove, 20mm, 12VDC	1
299	810027	BBCP	816551	FBB	810027W	W770	Head, Complete	1

EXPLODED VIEW

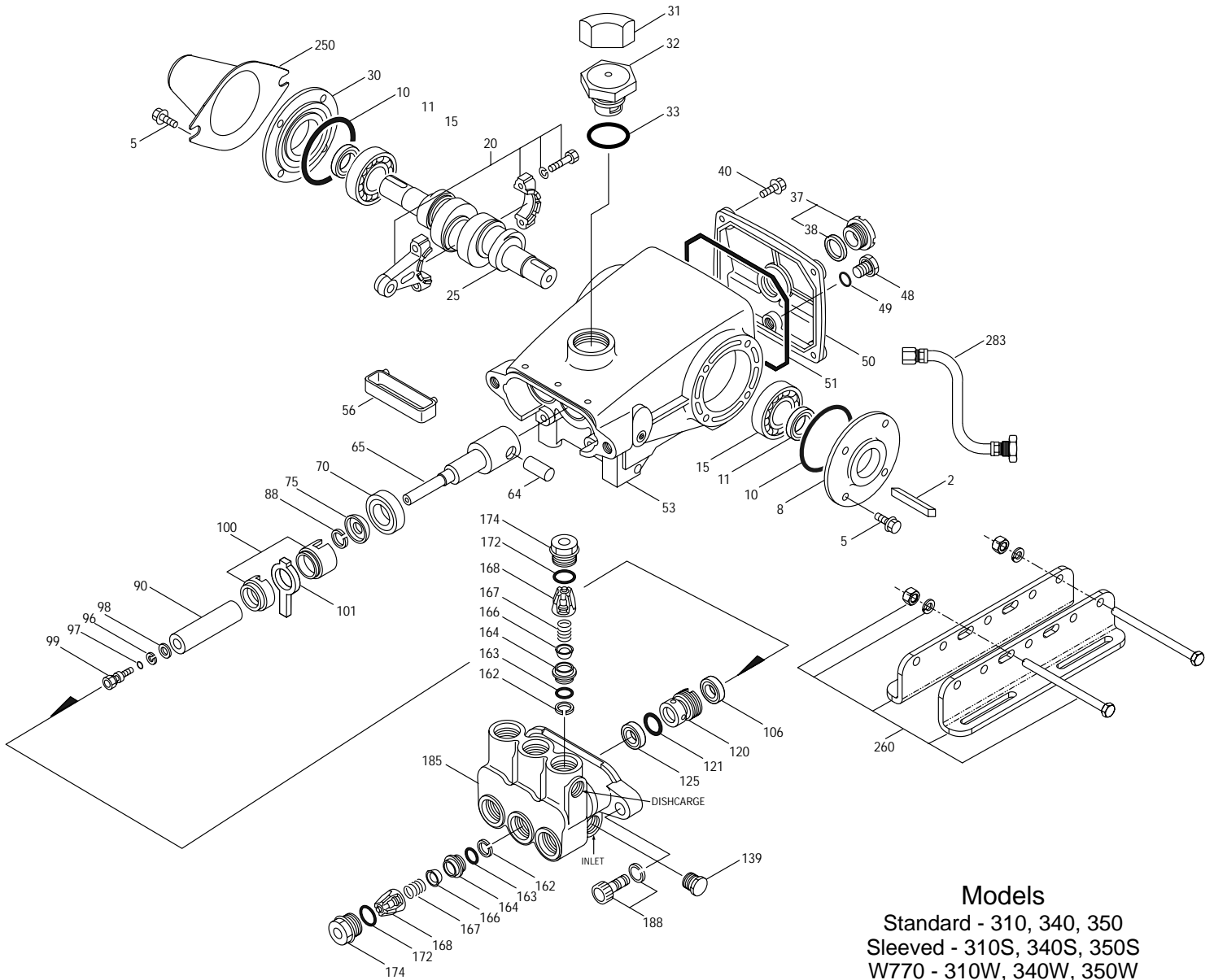

Models
 Standard - 310, 340, 350
 Sleeved - 310S, 340S, 350S
 W770 - 310W, 340W, 350W
 October 2006

	310	310S	310W				
	340	340S	340W				
	350	350S	350W	MATL	MATL		
300	30623	30623	30623	NBR	NBR	Kit, Seal (Incls: 97,101,106,121,125)	1
	34155	34155	34155	FPM	FPM	Kit, Seal (Incls: 97,101,106,121,125)	1
	33623	33623	33623	HT	HT	Kit, Seal, "Hi-Temp" (Incls: 97,101,106,121,125)	1
	◆ 31163	◆ 31163	◆ 31163	EPDM*	EPDM*	Kit, Seal (Incls: 97,101,106,121,125)	1
310	30821	30821	30821	NBR	NBR	Kit, Valve (Incls: 162-164,166-168,172)	2
	31821	31821	31821	FPM	FPM	Kit, Valve (Incls: 162-164,166-168,172)	2
	◆ 31162	◆ 31162	◆ 31162	EPDM	EPDM	Kit, Valve (Incls: 162-164,166-168,172)	2
350	30696	30696	30696	STZP	STZP	Plier, Reverse	1
351	33004	33004	33004	STZP	STZP	Socket, Seal Case (1/2" Drive)	1
—	—	—	—	—	—	BD Motors - See Individual Data Sheet	
—	6107	6107	6107	—	—	Oil, Bottle (21 oz.) ISO 68 Multi-viscosity Hydraulic (Fill to specified crankcase capacity prior to start-up)	1

Bold print part numbers are unique to a particular pump model. Italics are optional items. ◆Silicone oil/grease required. R Components comply with RoHS Directive.
 [] Date of latest production change. *Review material codes for individual items (HT generally may be used as alternate). Add .3000 to part numbers for Hi-Temp model.
 See Tech Bulletins 002, 003, 008, 024, 027, 032, 035, 036, 043, 045, 046, 049, 052, 053, 054, 073, 074, 077, 079, 083 and 090 for additional information.
 MATERIAL CODES (Not Part of Part Number): ABS=ABS Plastic AL=Aluminum BB=Brass BBCP=Brass/Chrome Plated CC=Ceramic CM=Chrome-moly CU=Copper
 D=Acetal EPDM=Ethylene Propylene Diene Monomer FBB=Forged Brass FCM=Forged Chrome-moly FPM=Fluorocarbon HS=High Strength
 HT=High Temp (EPDM Alternative) NBR=Medium Nitrile (Buna-N) POP=Polypropylene PTFE=Pure Polytetrafluoroethylene PVDF=Polyvinylidene Fluoride S=304SS
 SNG=Special Blend (Buna) SS=316SS STL=Steel STCP=Steel/Chrome Plated STZP=Steel/Zinc Plated W770=Special Alloy ZZCP=Chrome Plated/Steel - Zamak

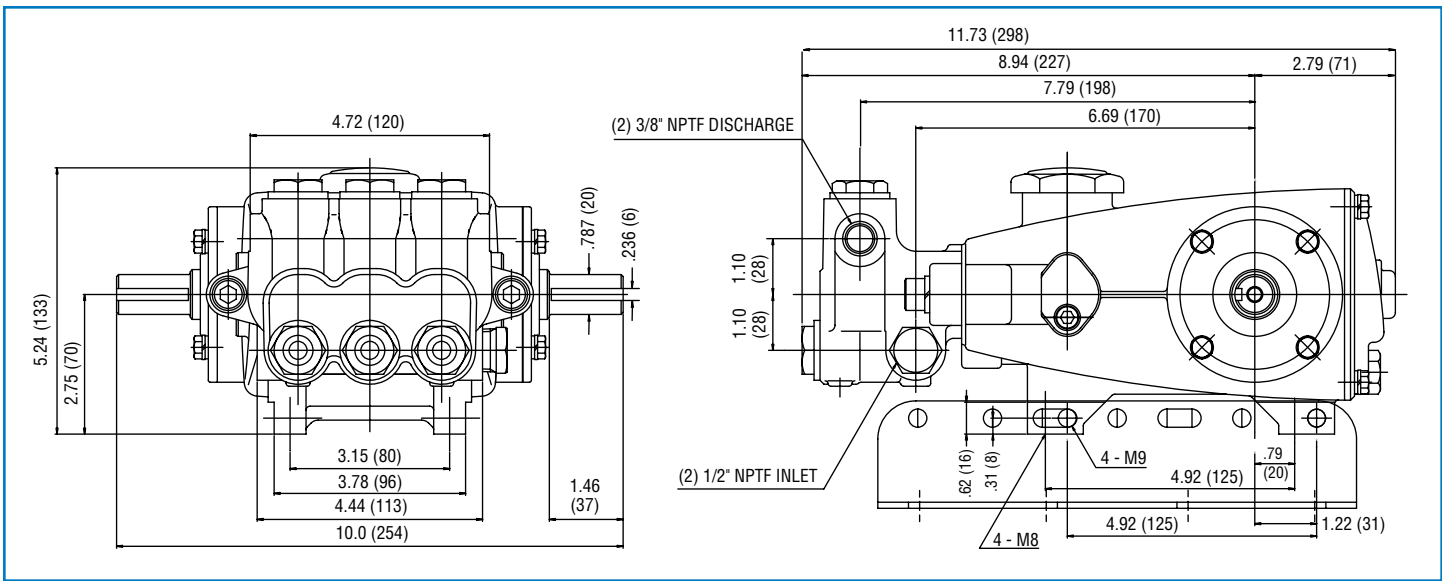

Models 310, 340, 350, 310S, 340S, 350S, 310W, 340W, 350W

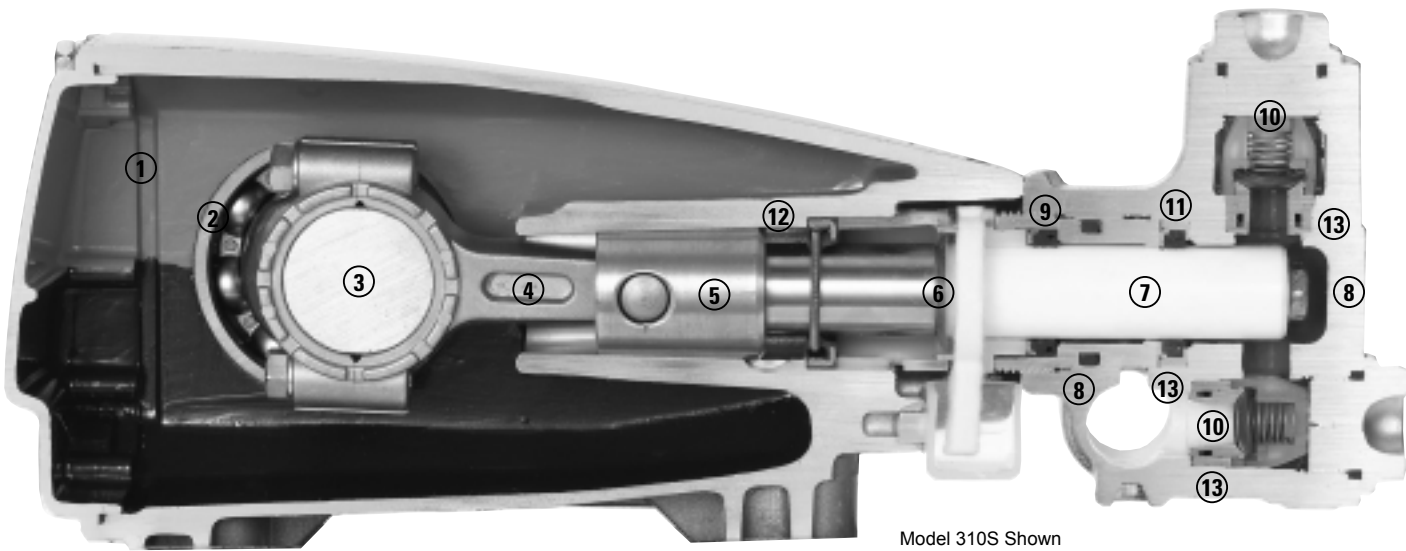

Model 310S Shown

- 1 Die cast aluminum **crankcase** means high strength, lightweight, and excellent tolerance control.
- 2 Oversized crankshaft **bearings** provide extended bearing life and pump performance.
- 3 Chrome-moly **crankshaft** provides unmatched strength and surface hardness for long life.
- 4 Matched oversized high strength **connecting rods** noted for superior tensile strength and bearing quality.
- 5 Special high strength **plunger rods** with Zamak crossheads for longevity and corrosion resistant.
- 6 The stainless steel **slinger** provides back-up protection for the crankcase seal, keeping pumped liquids out of the crankcase.
- 7 Special concentric, high-density, polished, solid ceramic **plungers** provide a true wear surface and extended seal life.
- 8 **Manifolds** are a high tensile strength forged brass, 316 stainless steel sleeved or W770 alloy for long life, continuous duty and compatibility.
- 9 100% wet **seal** design adds to service life by allowing pumped liquids to cool and lubricate on both sides.
- 10 Stainless steel **valves, seats and springs** provide corrosion-resistance, ultimate seating and extended life.
- 11 Specially formulated, CAT PUMP exclusive, **Hi-Pressure Seals** offer unmatched performance and seal life.
- 12 **Crossheads** are 360° supported for uncompromising alignment.
- 13 Precision, press-fit, **304 stainless steel sleeves** in both the seal and valve chambers provide extended life (S models only).

World Headquarters

CAT PUMPS

1681 - 94th Lane N.E. Minneapolis, MN 55449-4324

Phone (763) 780-5440 — FAX (763) 780-2958

e-mail: techsupport@catpumps.com

www.catpumps.com

International Inquiries

FAX (763) 785-4329

e-mail: intlsales@catpumps.com



The Pumps with Nine Lives

CAT PUMPS (U.K.) LTD.

1 Fleet Business Park, Sandy Lane, Church Crookham, Fleet

Hampshire GU52 8BF, England

Phone Fleet 44 1252-622031 — Fax 44 1252-626655

e-mail: sales@catpumps.co.uk

N.V. CAT PUMPS INTERNATIONAL S.A.

Heiveldekens 6A, B-2550 Kontich, Belgium

Phone 32-3-450.71.50 — Fax 32-3-450.71.51

e-mail: cpi@catpumps.be www.catpumps.be

CAT PUMPS DEUTSCHLAND GmbH

Buchwiese 2, D-65510 Idstein, Germany

Phone 49 6126-9303 0 — Fax 49 6126-9303 33

e-mail: catpumps@t-online.de www.catpumps.de